

POPSICLE

BY FLEXA

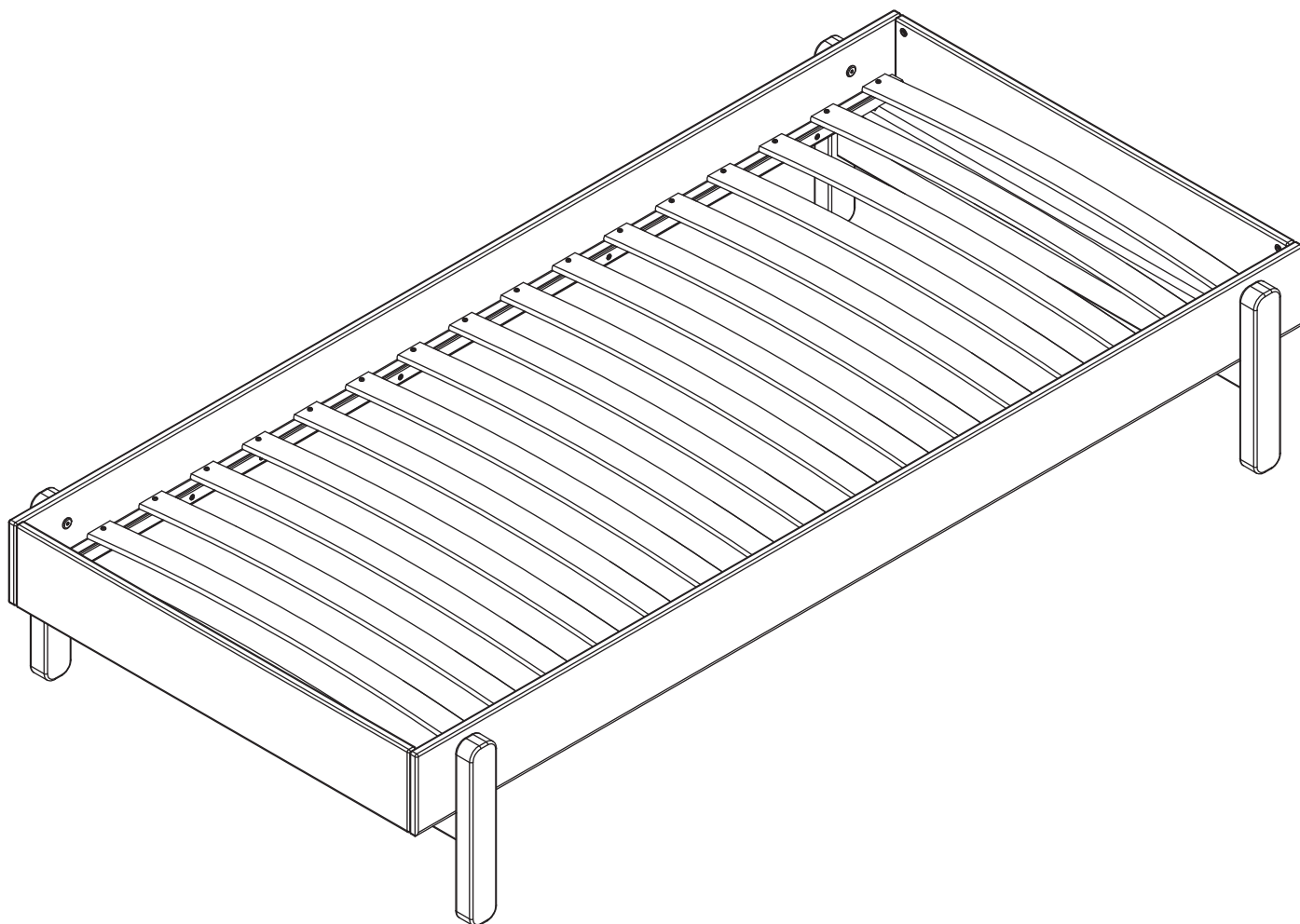

80-24101-31/-32/-33

For indoor
domestic use

FLEXA[®]
Designed in Denmark, made in Europe

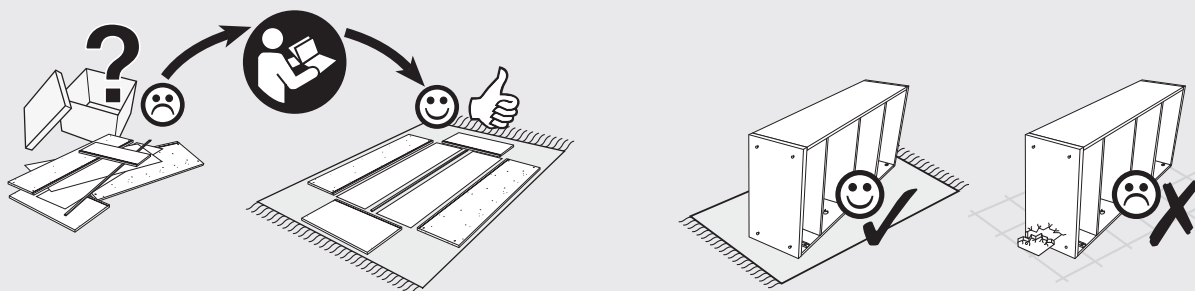
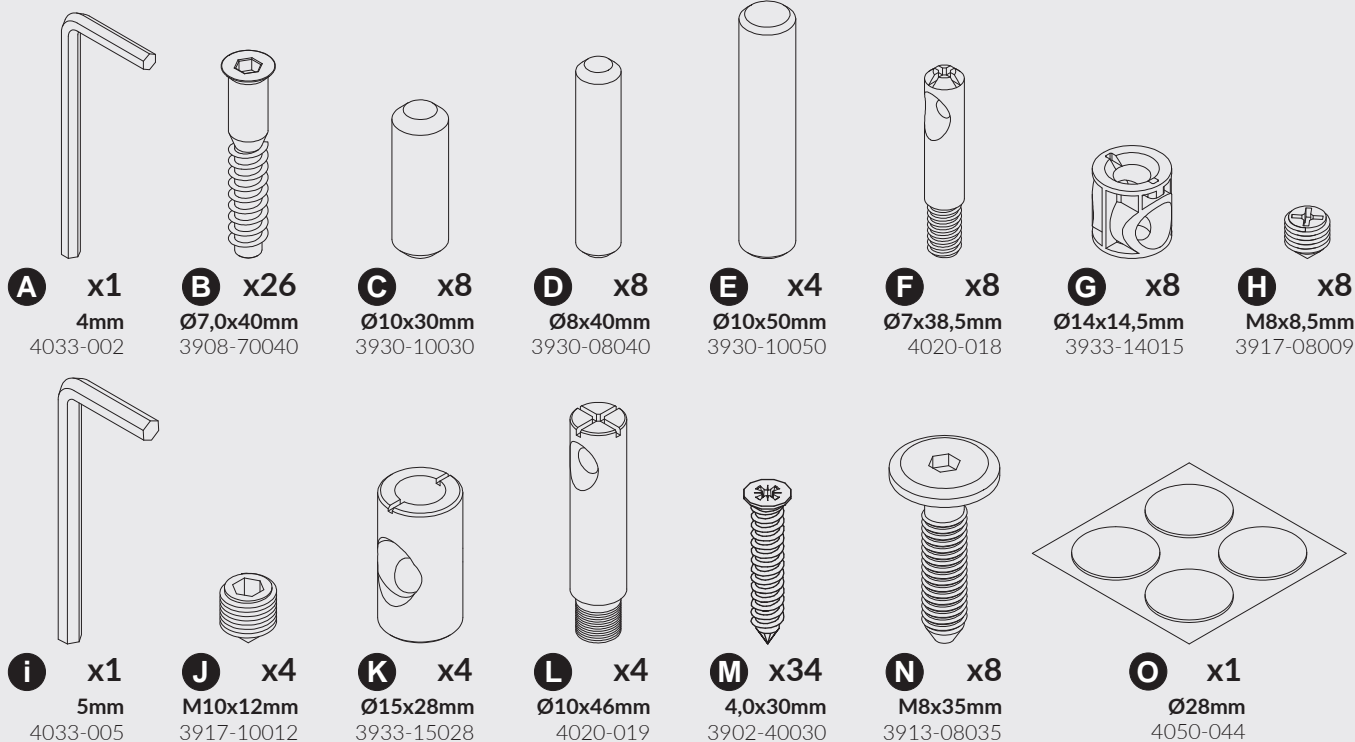

200cm

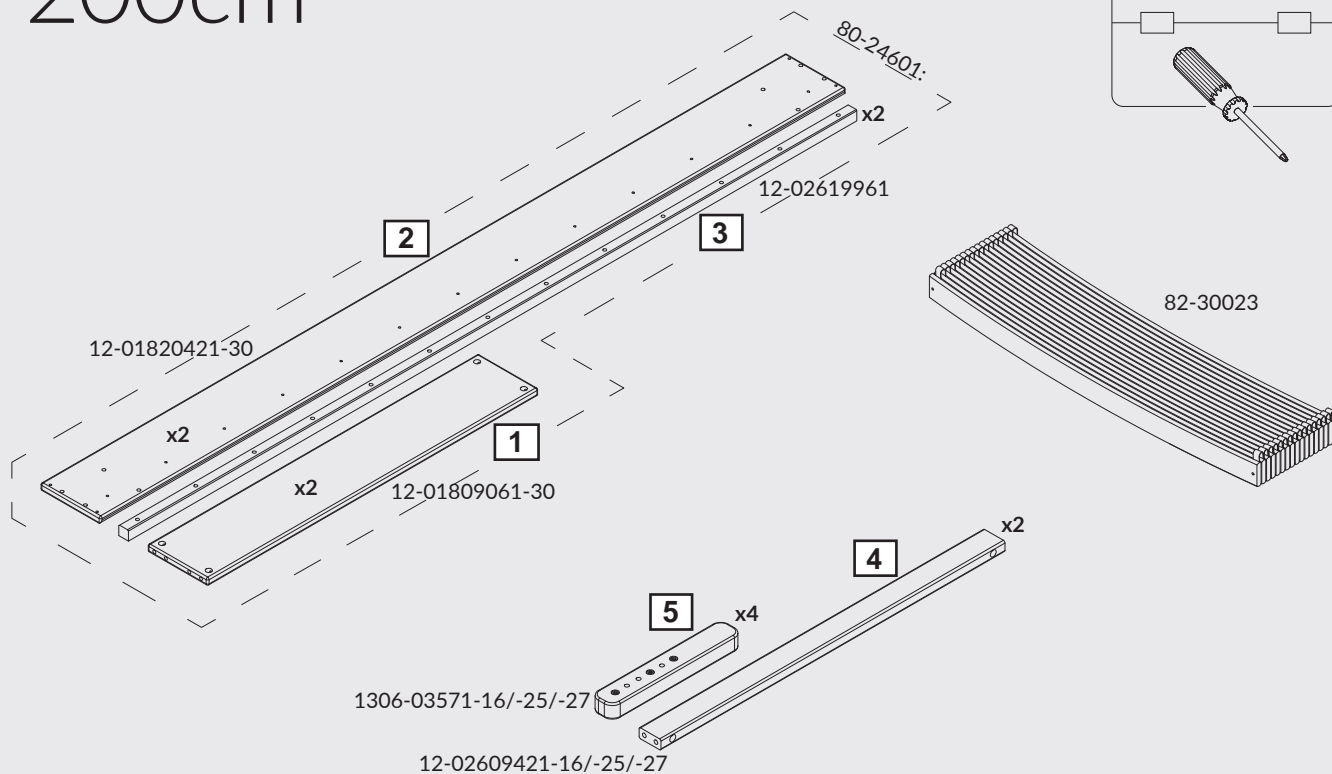

1

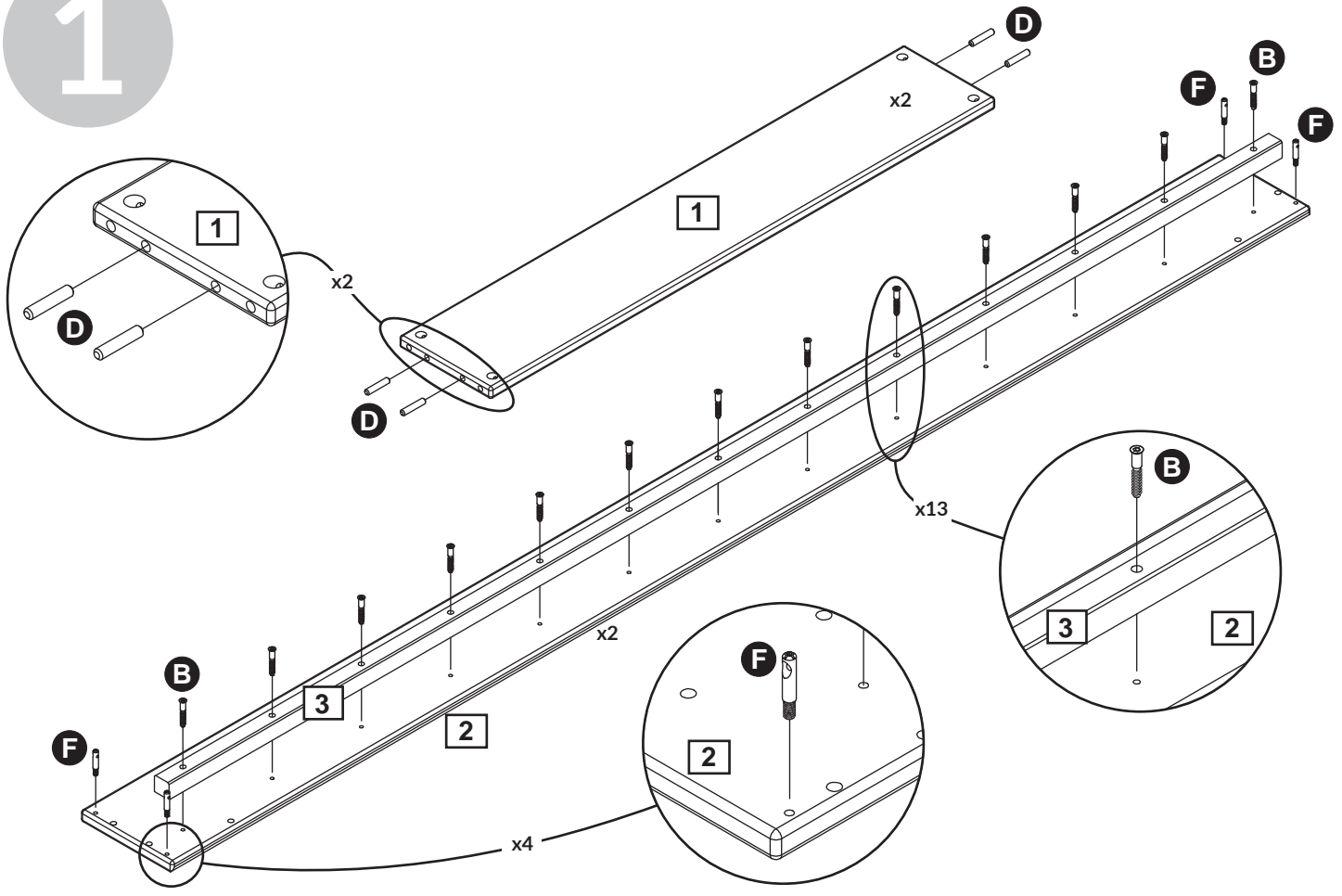

2

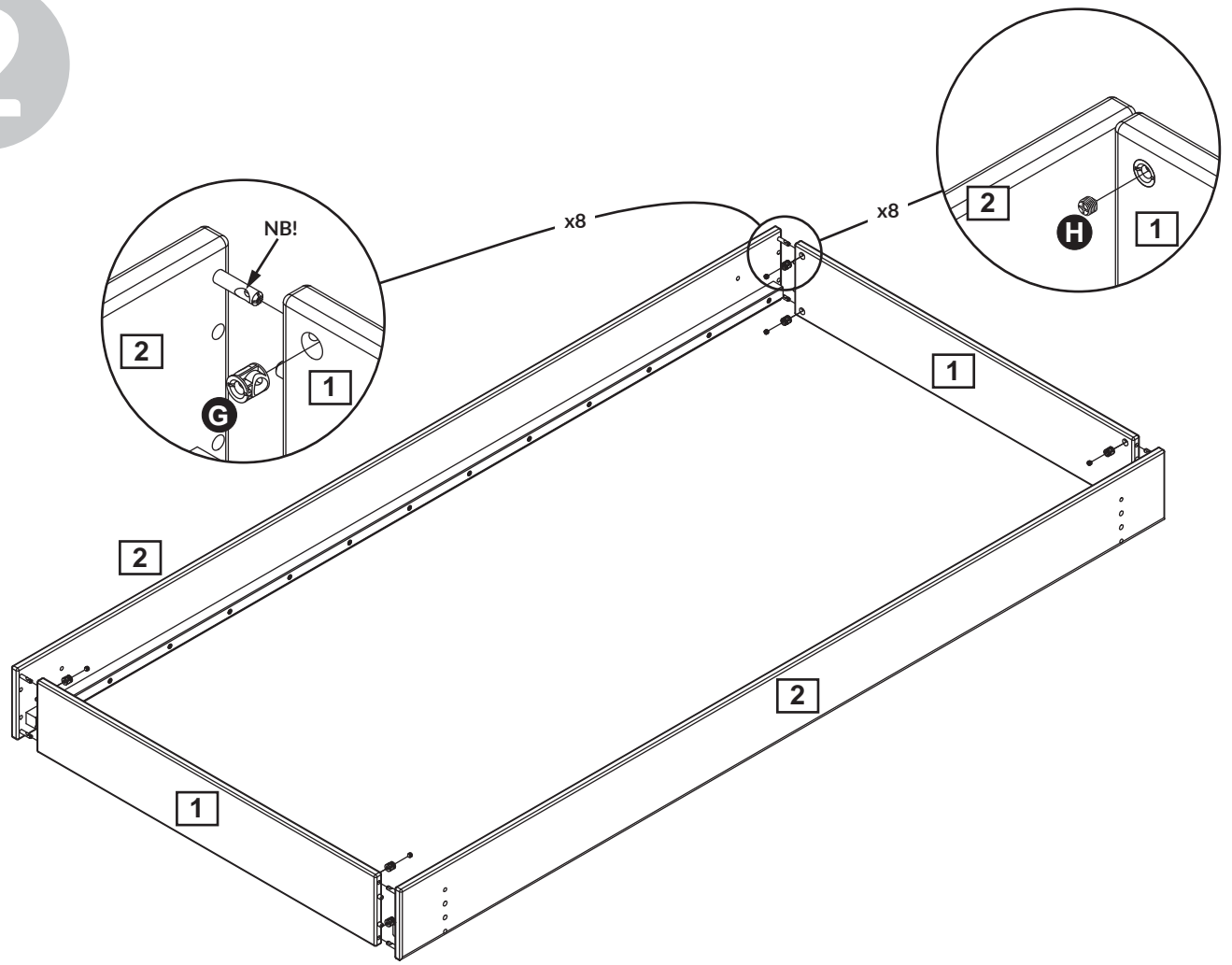

3

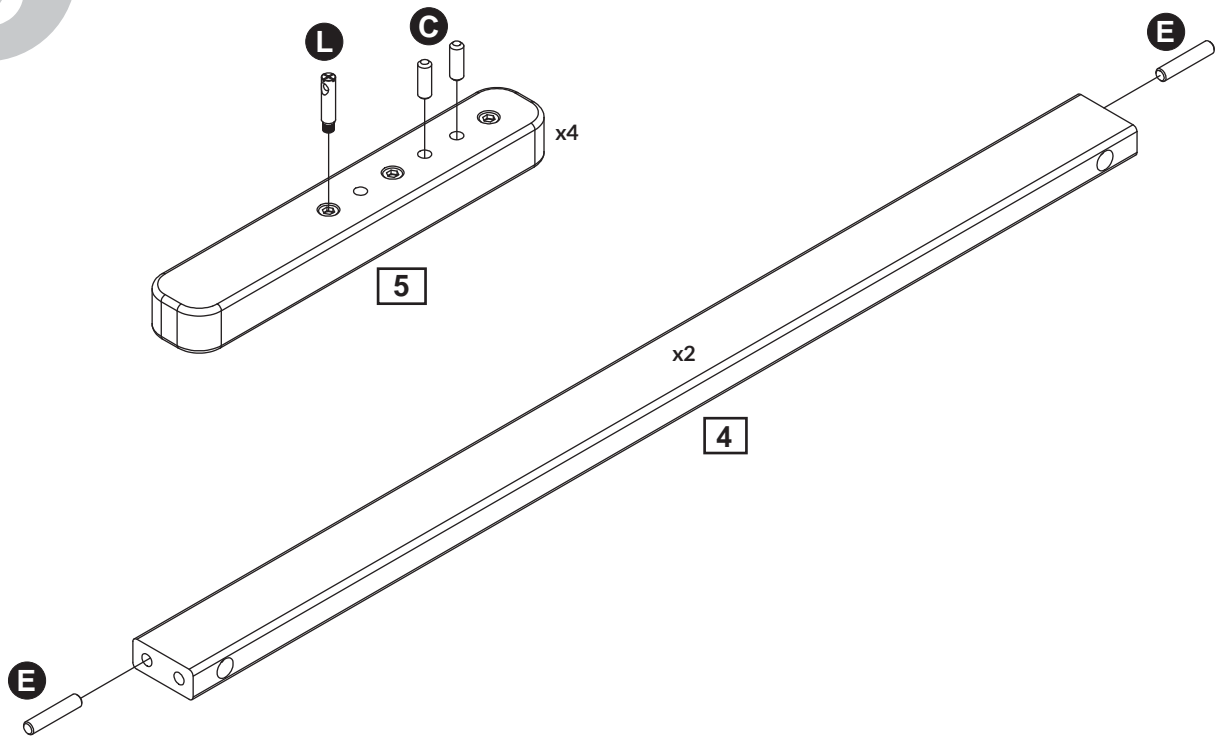

4

x2

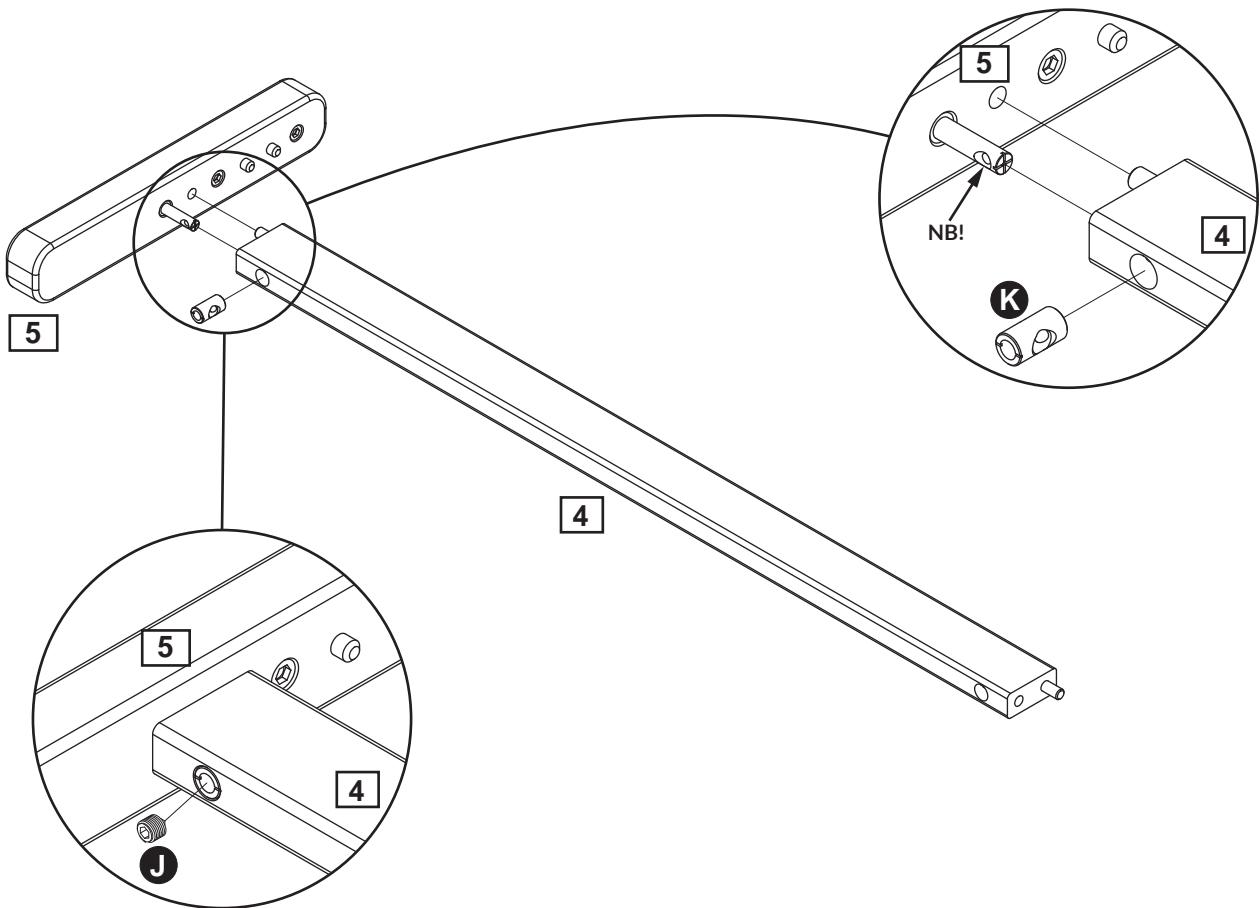

5

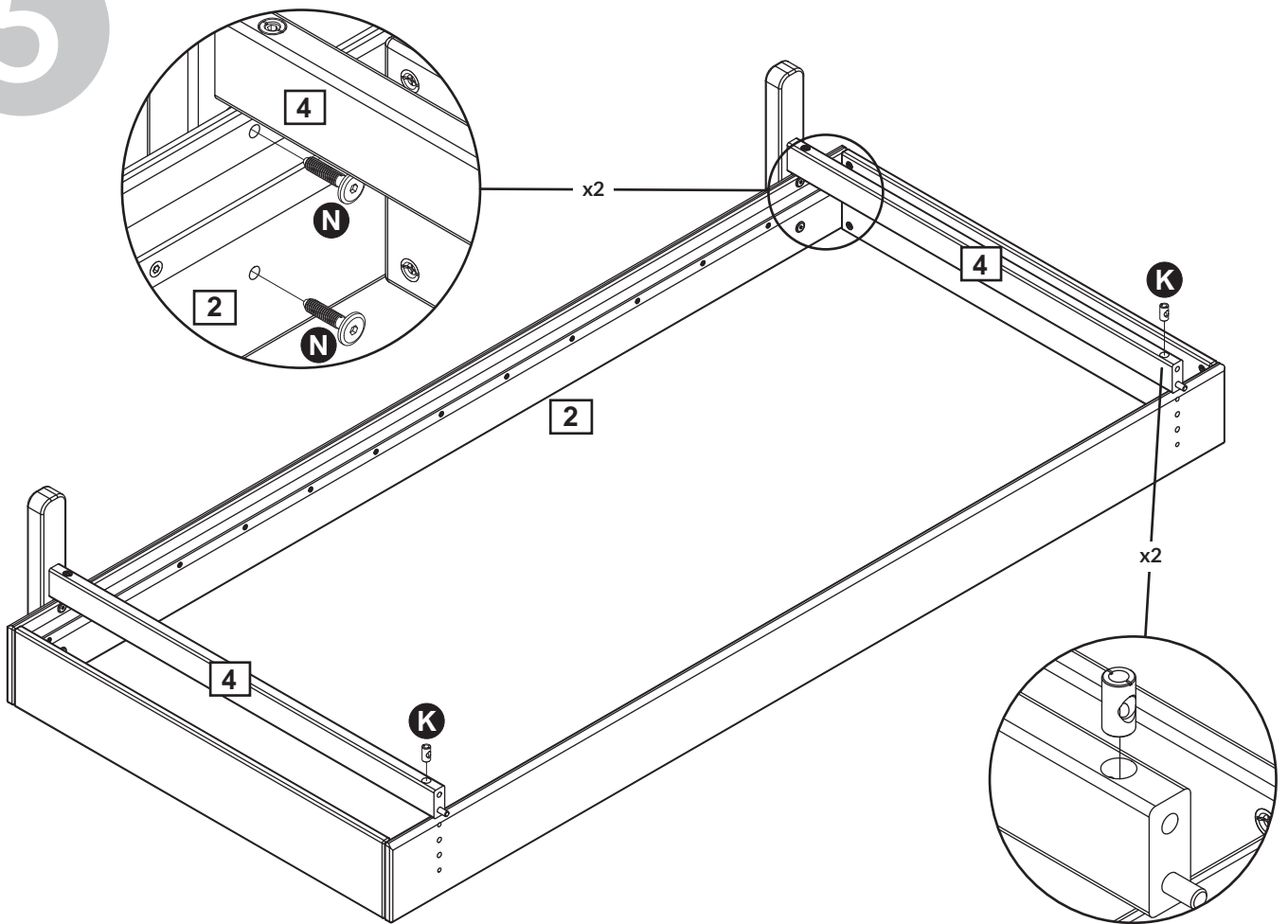

6

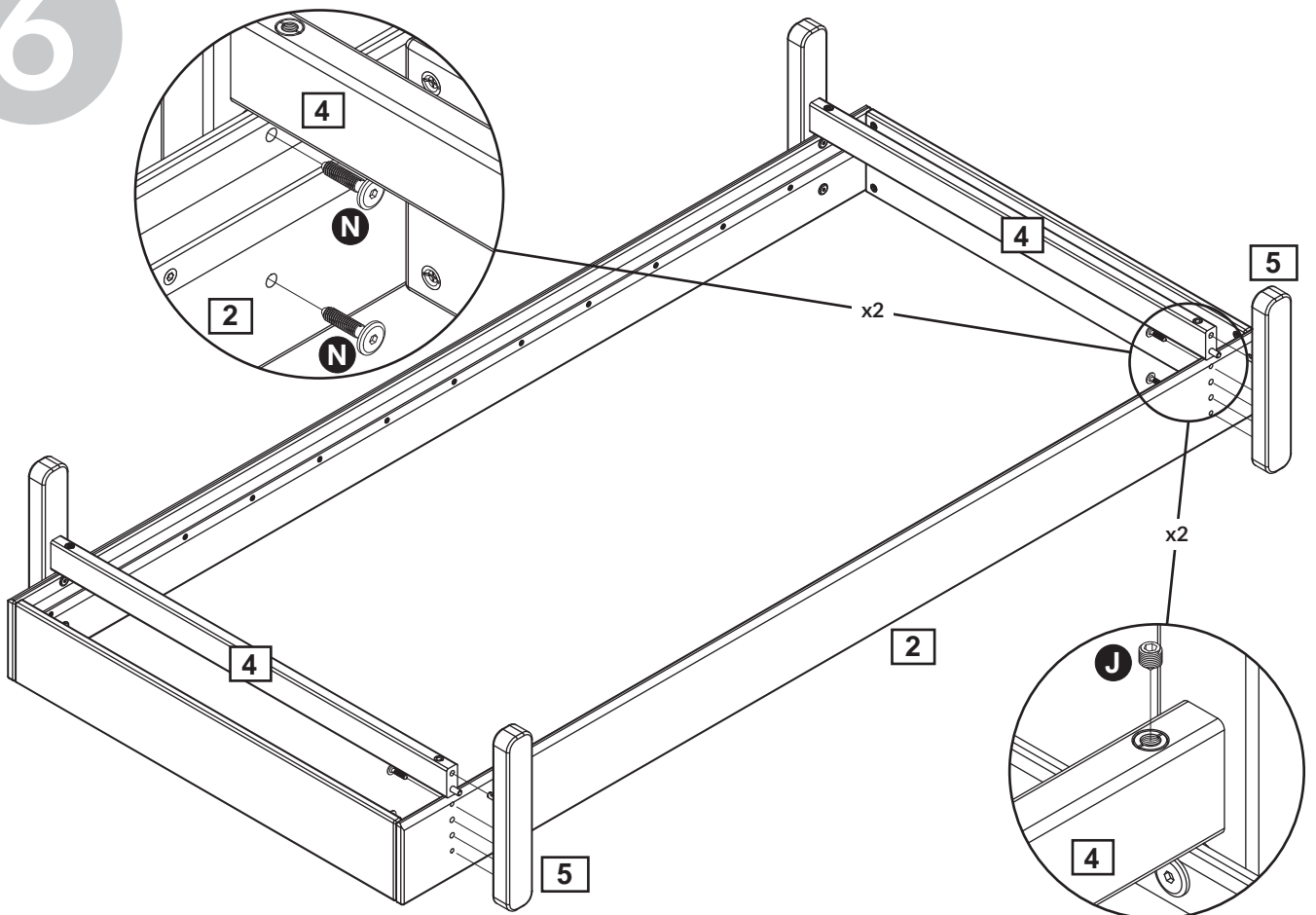



Product Declaration

Product: Children's furniture

Product No: Please refer to the label or the Assembly and User Instruction. The product code refers to the type, length and color of the product. As an example the item number 80-01101-1, a single bed, 80-01101 - 190cm long, 80-01101-1-clear lacquered. 80-01102-2, a single bed, 80-01102- 200cm long, 80-01102-2 · white lacquered.

Technical

character and size: Please refer to the Assembly and User Instruction.

Main material: European solid oak wood and oak veneer

Lacquer: Water soluble UV lacquer complying with the EN standard

Glue: Glue complying with the EN standard

Metal parts: Coating complying with the EN71 standard, part 3

Production date: Please refer to the label on the outer package.

Furniture products from FLEXA® are tested according to relevant European and American safety standards, e. g. EN, CE, GS, and CFR. Furthermore, FLEXA's products are tested by the China National Quality Supervision Center for Furniture and complying with the GB28007-2011 children furniture standard in China and other relevant standards. Also, we comply with the EN717 concern the formaldehyde release.

Assembly

and spare parts: Please refer to the Assembly and User Instruction.

Maintenance: Please refer to the Assembly and User Instruction.



Safety tested FLEXA furniture is made for children. We have carefully checked every single detail so you can safely set up your child's bedroom. For example, there are no sharp edges or corners on FLEXA furniture- they are all rounded. All beds with a sleeping height of more than 60 cm are safety tested according to the EU standard EN:747 by TUV.



Quality materials FLEXA insists on the highest quality and sustainability as a standard when we make furniture. For example, we only use the highest quality oak from sustainable forests in Europe. We are thereby ensuring that only the very best material is used for our furniture.



5-year guarantee FLEXA's aim is always to deliver the highest quality and safety. That is why we provide a 5-year guarantee against manufacturing defects on all our furniture. The guarantee does not cover damage to the lacquer surface caused by knocks or wear and tear.



5-year availability guarantee on our bed system When you purchase a bed from the FLEXA Classic bed system, you buy a flexible system than can be altered and extended as and when the need arises. We offer a 5-year availability guarantee on the current FLEXA Classic bed system. If a product is no longer in our product range, the 5 year-availability guarantee still applies from the date the product is discontinued. We will notify your dealer.



Lacquer FLEXA furniture is surface treated with lacquer several times to give our furniture an optimal and elegant finish. At the same time it makes our furniture robust and more resistant to signs of wear and tear. FLEXA is only using eco-friendly water-based lacquer and UV lacquer, which meets the EU standard for lacquer.



Colour differences Many FLEXA furniture is made of solid wood or part of it is in solid wood and natural differences in colour may appear between individual products. This is only natural since wood is a living product. All FLEXA textiles are made of natural products. Natural differences in colour may occur.



Non-toxic furniture FLEXA cherishes the health of your child, given that all FLEXA furniture is tested according to the strict international safety standards EN71-3, DIN717-3 and DIN 53160. Your guarantee of non-toxic furniture.

Children's furniture from the Danish company, FLEXA, is designed by FLEXA according to Scandinavian design traditions. The wood furniture are manufactured by FLEXA in Europe and sold worldwide.

FLEXA® and the FLEXA® logo are trademarks of Flexa4Dreams Holding A/S.

**For three years old or above.
Only for adult to assemble.**

Manufacturer: FLEXA4Dreams Holding A/S, Denmark

Address: Hornsyld Industrivej 4, 8783 Hornsyld, Denmark

Tel: +45 7668 8055 **Fax:** +45 7668 8069

Email: flexa@flexa.dk

Website: www.flexaworld.dk



产品说明书

产 品 编 号: 儿童家具。
产 品 编 号: 参见标签或包装内的安装及使用说明。产品编号代表产品的类型、长度和颜色。例如:80-01101-1, 为基本床, 80-01101-190cm, 80-01101-1-本色。80-01102-1, 为基本床。80-01102-200cm, 80-01102-2-白色。

技术特征和尺寸: 见安装及使用说明。

主 料: 欧洲实木橡木和橡木贴面。

油 漆: 水溶性UV漆, 符合EN标准。

胶 水: 胶水符合欧洲质量标准。

金 属 配 件: 镀层符合欧洲玩具安全标准EN71, 第三部分。

芙莱莎集团出品的家具经过欧洲和美国最严格的安全测试, 符合EN, CE, GS, CFR 标准, 芙莱莎的产品经过国家家具质量监督检验中心的检测, 符合儿童家具通用技术条件GB28007-2011——目前国内唯一的儿童家具国家强制标准和其他相关国家标准。同时我们符合欧洲标准EN717中针对甲醛释放的要求。

安 装 及 配 送: 见安装及使用说明。

日 常 维 护 保 养: 见安装及使用说明。



安全保证 芙莱莎专为儿童制造, 我们专注于每一个细节, 以确保您可以安心布置儿童房, 例如, 芙莱莎儿童家具全无尖锐的边和角, 所有边角都作磨圆处理; 所有高度超过60厘米的床都要经过德国莱茵的高层床检测标准EN:747。



高品质的木材 芙莱莎始终将只使用高品质和可持续使用的木材作为标准。例如: 我们只在欧洲可持续发展的森林里挑选高品质橡木, 这样我们可以确保我们制作的儿童家具材料来源于优质木材。



五年质保 芙莱莎的目标是提供始终如一的高品质和安全性, 因此芙莱莎推出5年质保服务, 但仅针对家具生产制造过程中造成的缺陷, 不针对漆面的损伤。



床系统五年质保—如果您购买了芙莱莎经典系列床系统, 您就购买了一套在需要时可以变换及延展的灵活系统。我们为芙莱莎经典系列床系统提供五年质保。如果产品已经退市, 五年质保自宣布退市起始日开始计算。我们将及时通知经销商。



掉 漆 芙莱莎儿童家具的表面都用水溶性UV漆涂刷好几遍, 以确保家具的最佳呈现, 同时, 可以让家具更加耐磨耐损。芙莱莎所使用的水溶性UV漆达到EU标准。



自然色差异 芙莱莎家具由纯松木制成, 由于实木具有活性, 因此会存在天然的色差, 所有芙莱莎纺织品也由天然材料制成, 因此也会存在色差。



芙莱莎家具 为了您的孩子身心健康考虑, FLEXA家具无毒无害。FLEXA家具产品符合所有必要的安全标准, 包括严苛的EN71-3重金属欧盟标准; 欧盟717-3甲醛检测标准; DIN53160耐汗唾液色牢度测试。

芙莱莎儿童家具产自丹麦, 依照斯堪的纳维亚风格所设计。芙莱莎实木家具均由欧洲生产, 然后发往全球销售。

芙莱莎® 和FLEXA® 是Flexa4Dreams Holding A/S (芙莱莎)集团的注册商标。

**适用于三岁以上年龄
只允许成人安装, 儿童勿近**

生产商: FLEXA4Dreams Holding A/S, Denmark

地 址: Hornsyld Industrivej 4, 8783 Hornsyld, Denmark

电 话: +45 7668 8055 **传真:** +45 7668 8069

邮 箱: flexa@flexa.dk

网 址: www.flexaworld.dk