

STORAGE UNIT

— Created by FLEXA —



88-13742-x

For indoor
domestic use

ASSEMBLY MANUAL

FLEXA®

STORAGE UNIT 88-13742-100

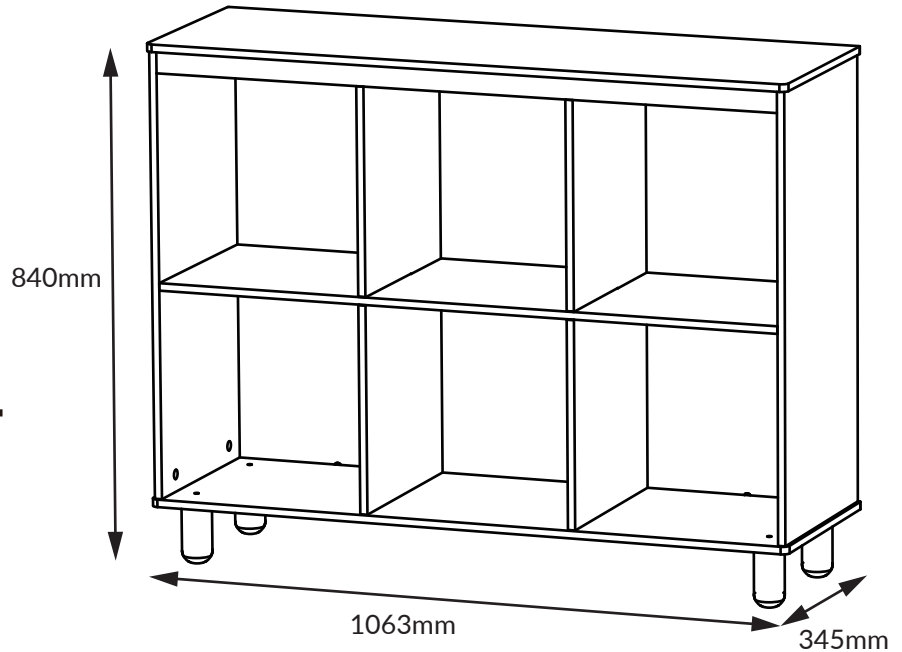

RÅD OM VELIGEHOLDELSE:

Tør af med en fugtig klud. Evt. større pletter fjernes med en fugtig svamp med sæbe. Undgå opløsningsmidler. Skruer og bolte efterspændes med jævne mellemrum.

MAINTENANCE INSTRUCTIONS:

Cleaning with a wet cloth, use a sponge with soap to remove obstinate dirt. Avoid solvents and dilutions. Screws and bolts should from time to time be retightened.

WARTUNGSANLEITUNG:

Mit einem feuchten Lappen säubern, nutzen Sie einen mit Seife getränkten Schwamm für hartnäckigere Verschmutzungen. Nutzen Sie keine Lösungsmittel oder Verdünner. Schrauben und Bolzen sollten gelegentlich neu festgezogen werden.

INSTRUCTIONS D'ENTRETIEN:

Nettoyage avec un tissu humide, utilisez une éponge avec du savon pour enlever la poussière obstinée. Évitez les solvants et les dilutions. Les vis et les boulons doivent être resserrés de temps en temps.

INSTRUCCIONES DE MANTENIMIENTO:

Limpieza con paño húmedo, use una esponja con jabón para remover la suciedad difícil de quitar. Evite solventes y diluciones. Los tornillos y pernos deben reajustarse ocasionalmente.

ONDERHOUDSINSTRUCTIES:

Schoonmaken met een vochtige doek, gebruik een spons met zeep voor het verwijderen van hardnekkig vuil. Vermijd oplossings- en verdunningsmiddelen. Schroeven en bouten regelmatig aandraaien.

LA MANUTENZIONE:

Pulire con un panno umido, usare una spugna con sapone per rimuovere lo sporco ostinato. Evitare solventi e diluizioni. Viti e bulloni devono di volta in volta essere riavvitati.

HOITO-OHJEET:

Puhdistetaan kostealla kankaalla, lian poistamiseen voidaan käyttää sientä ja saippuaa. Vältä liuotainaineita ja laimennoksia. Ruuvit ja pultit tulee kiristää säännöllisin väliajoin.

ΟΔΗΓΙΕΣ ΣΥΝΤΗΡΗΣΗΣ:

Καθαρίζετε το προϊόν με ένα υγρό πανί και χρησιμοποιήστε ένα σφουγγάρι με σαπούνι για να απομακρύνετε την επίμονη βρωμιά. Αποφύγετε τη χρήση διαλυτικών και διαλυμάτων. Οι βίδες και τα μπουλόνια θα πρέπει να ξανασφίγγονται ανά διαστήματα.

INSTRUKCJE KONSERWACJI: Czyścić przy pomocy wilgotnej ściereczki, gąbki z mydłem. Nie stosować rozpuszczalników i rozcieńczalników. Co jakiś czas należy dokręcać śruby i wkręty.

INSTRUÇÕES DE MANUTENÇÃO:

Limpe com um pano molhado. Use uma esponja com detergente para remover as manchas mais difíceis. Evite solventes e diluentes. Os parafusos e cavilhas deverão ser apertados de tempos a tempos.

INSTRUCȚIUNI DE ÎNTREȚINERE:

Se curățați cu un material textil umed, folosiți un burete cu săpun pentru a îndepărta mizeria persistentă. Evitați solvenții și diluanții. Șuruburile și buloanele trebuie retixate periodic.

ИНСТРУКЦИИ ПО УХОДУ:

Очищать влажной тканью, для удаления стойких загрязнений использовать губку с мылом. Избегайте использования растворителей и разбавителей. Шурупы и болты следует время от времени подтягивать.

维护说明：

用湿布清洁，用海绵沾肥皂清洁顽固污垢。避免使用溶剂和稀释液。应定期重新拧紧螺丝及螺栓。

手入れの仕方：

全体を絞った布で拭き、特に汚れがひどいところは洗剤とスポンジを使って洗い落とし下さい。強力な洗剤や薬品は使用しないで下さい。ねじやボルトが緩んだままになっていないように時々締め直して下さい。

유지관리 지침:

젖은 헝겊으로 세척하고, 얼룩을 제거할 때는 스폰지에 비눗물을 묻혀 사용하세요. 솔벤트나 희석제를 사용하지 마세요.

Manufactured by:
Flexa4Dreams A/S
Fredensgade 36
8000 Aarhus, Denmark
www.flexaworld.com





A x20

3933-15010

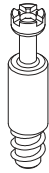

B x20

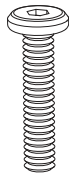

C x4

3913-06025-67

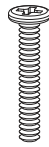

D x2

3902-40030

Spare Screws

A x2 **B** x2

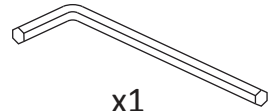

x1

4033-004

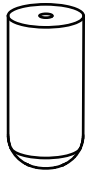

1 x4

1306-01001-x



2

4304-1210632-x

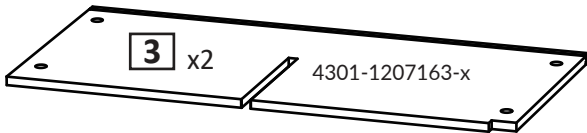

3 x2

4301-1207163-x

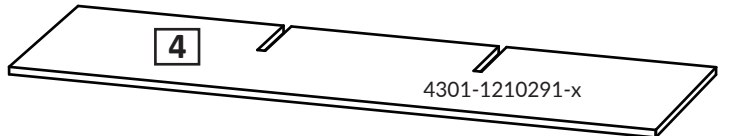

4

4301-1210291-x

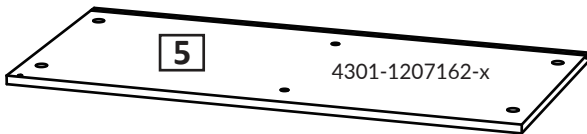

5

4301-1207162-x

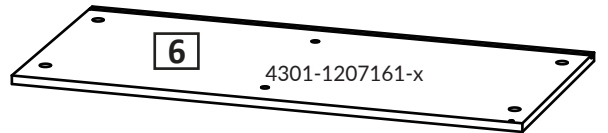

6

4301-1207161-x

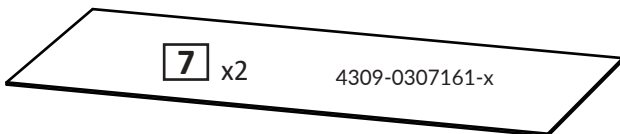

7 x2

4309-0307161-x

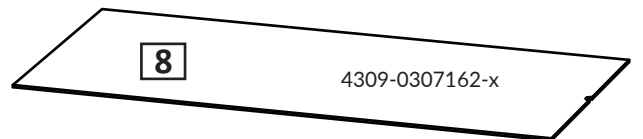

8

4309-0307162-x

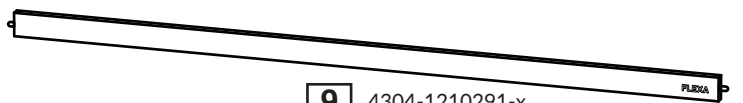

9

4304-1210291-x

FLS21A

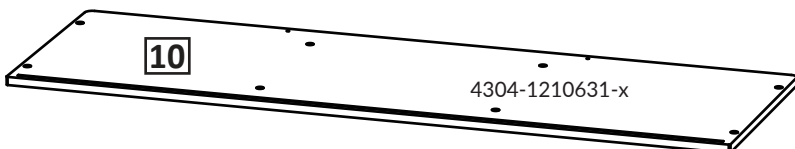

10

4304-1210631-x

1

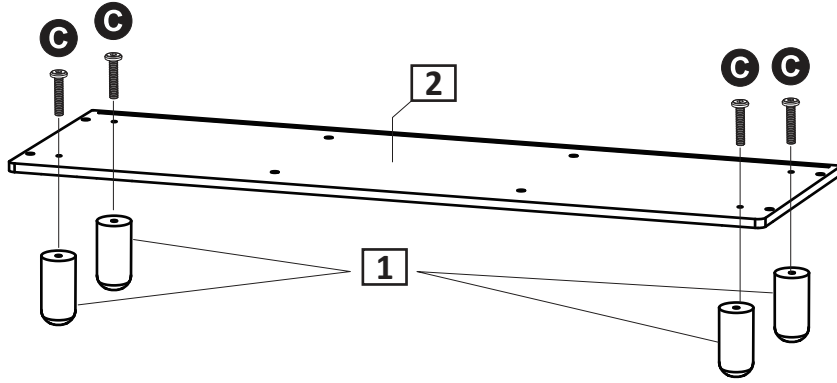

C x4



2

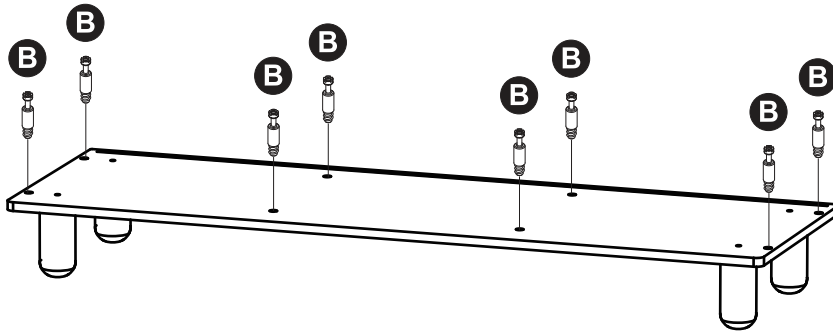

B x8



3

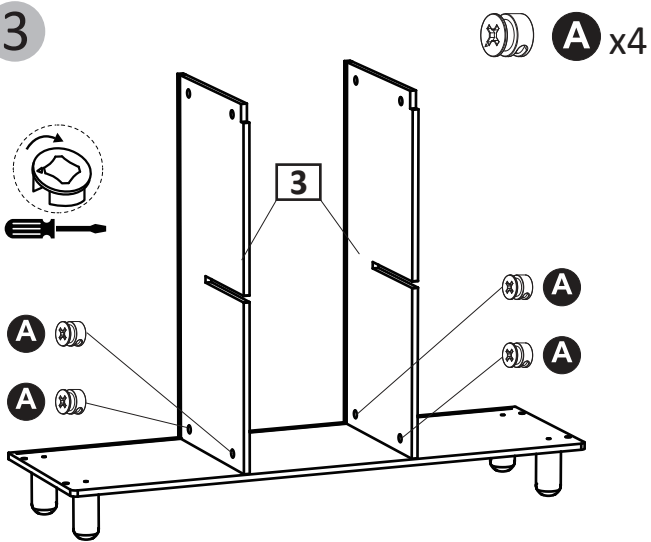

A x4

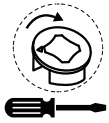

4

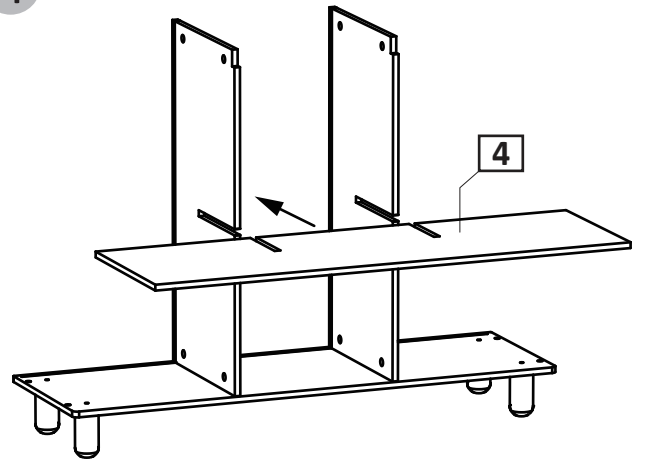

5

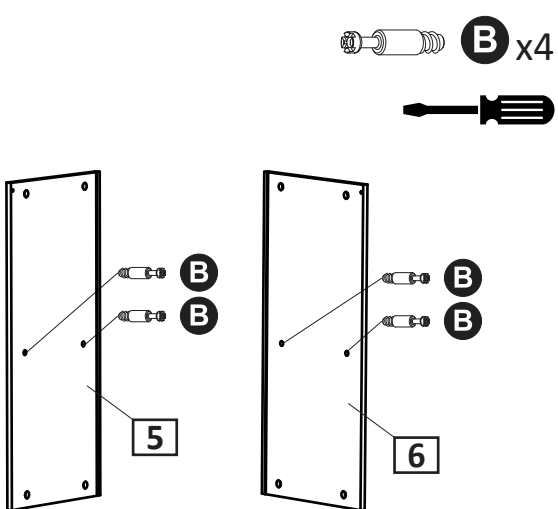

B x4



6

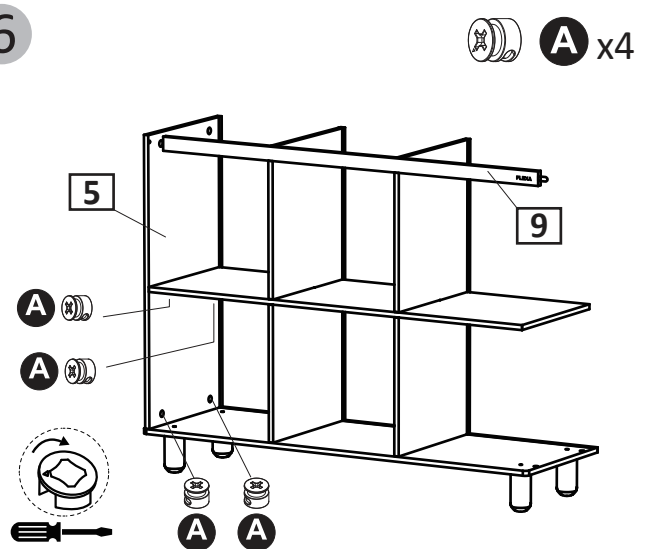

A x4



7

 **A** x4

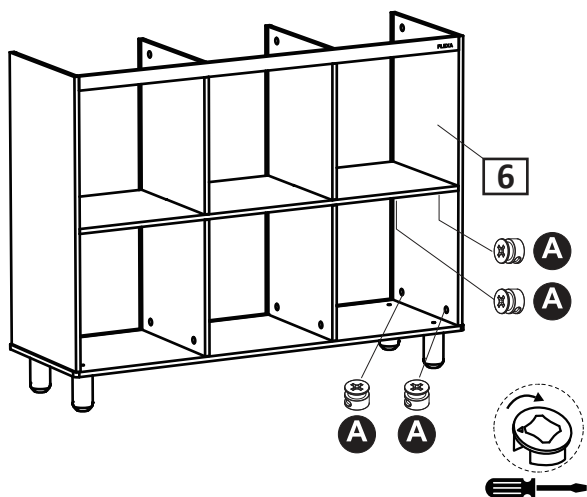

8

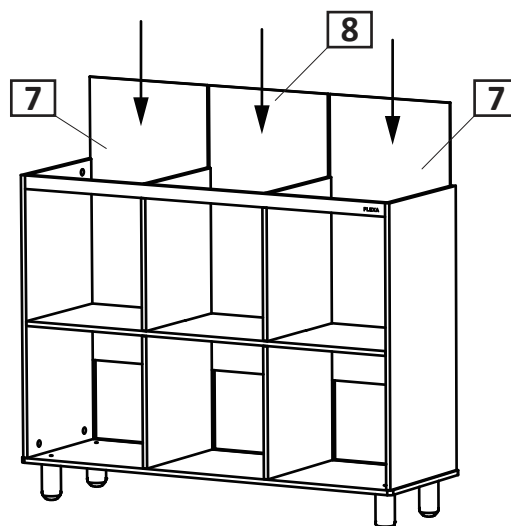

9

 **B** x8

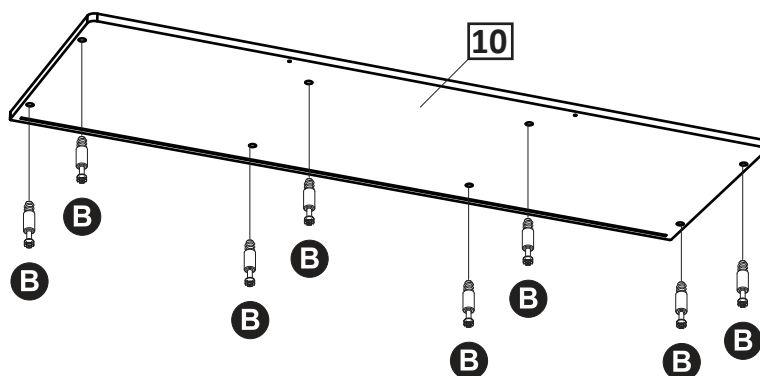

10

 **A** x8

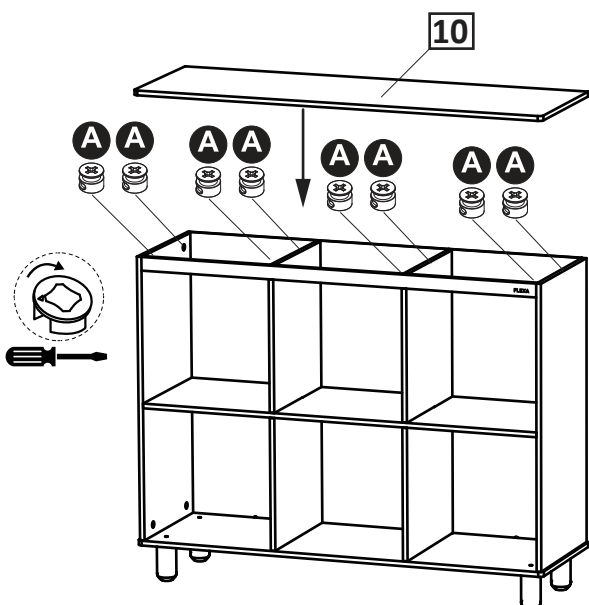

11

 **D** x2

